



Model No:
1150U
Professional Series
UNDERMOUNT SINK

www.oliverisinks.com



Model No: **1150U**
DIMENSIONS

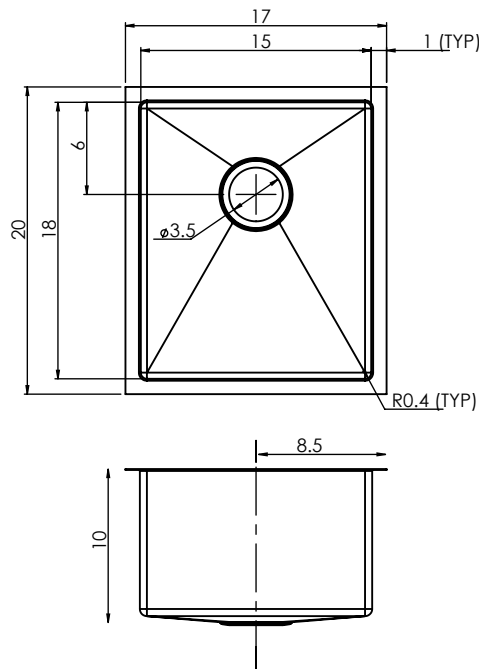

INCLUDED ACCESSORIES



Basket Waste x1

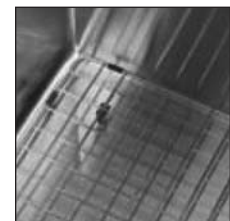

Basin Protector



<p>MATERIAL Stainless Steel 304 Grade 16 Gauge</p>	<p>CONSTRUCTION Fabricated bowl with 1/2" (10mm) internal radius corners</p>	<p>SHIPPING WEIGHT (Packed) 20lb</p>	<p>INSTALLATION METHOD Designed to be undermounted into a counter</p>	<p>CABINET Minimum 21"</p>
---	---	---	--	---



Head Office
Tasman Sinkware Pty Ltd
51 Naweena Rd, Regency Park
South Australia, 501
AUSTRALIA

North America
1230 Railroad St
Corona CA 92882
northamerica@oliverisinks.com

This sink is fabricated by a partner supplier according to Tasman Sinkware's specifications and quality standards