



Model No: 72U

70 Series

UNDERMOUNT SINK

Product Specifications

www.oliverisinks.com

MATERIAL

Stainless Steel
304 Grade
20 Gauge

CONSTRUCTION

Individual bowls
welded into rim

SHIPPING WEIGHT

(Packed)
13.0 lb

INSTALLATION METHOD

Designed to be
undermounted in
a solid surface top

CABINET

Minimum
27"

WARRANTY

All Oliveri sinks carry
Tasman sinkware's
Lifetime Limited
Buyer Warranty



Model No: 72U SINK DIMENSIONS

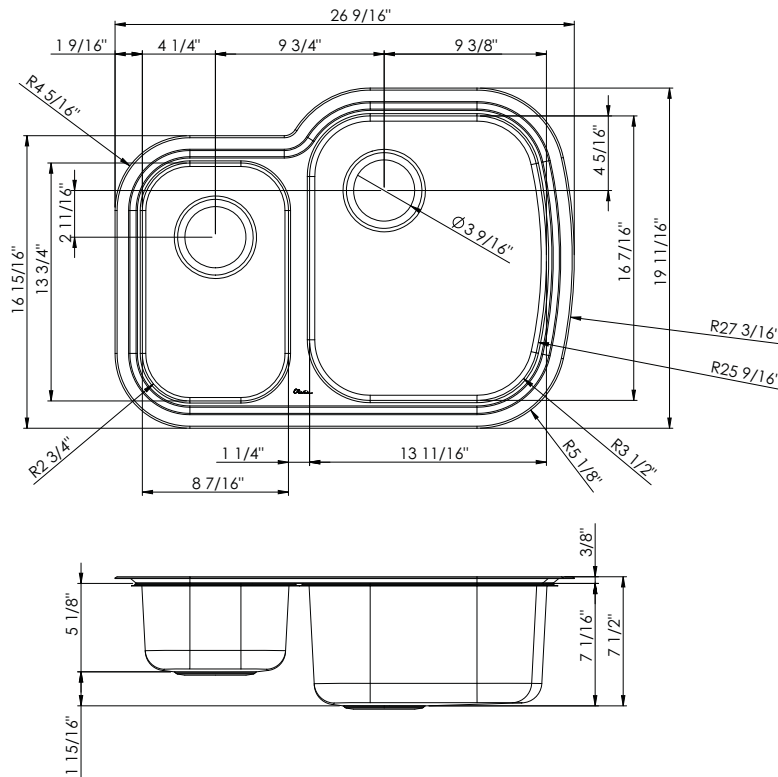

INCLUDED ACCESSORIES



AC09 Basket Waste x1



AC72W "D" Colander



AC73 Stainless Utility Tray

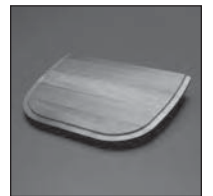

AC74 Timber Preparation Board

OPTIONAL ACCESSORIES



AC70



AC71

Undermount CAD files (DXF & DWG format) can be downloaded from our web site www.oliverisinks.com



Head Office and Manufacturing
Tasman Sinkware Pty Ltd
51 Naweena Rd. Regency Park
South Australia, 5010, AUSTRALIA
Tasman Sinkware

North America
1230 Railroad St
Corona CA 92882
northamerica@oliverisinks.com

Project / Customer Name: _____

Approval: _____

Date: _____