

## IMPORTANT – PLEASE READ THESE INSTRUCTIONS CAREFULLY BEFORE INSTALLING YOUR MIXER TAP

### NW7310-27 Single Lever Mixer

**THIS MIXER TAP MUST BE INSTALLED BY A LICENSED PLUMBER IN ACCORDANCE WITH LOCAL REGULATIONS**

This mixer tap is manufactured to standard AS/NZS 3718.  
**Max operating pressure 600 kPa.**  
**Min operating pressure 100 kPa**  
**Max Hot temperature 80°C**  
(Recommended 65°C)

**Where water pressure exceeds 600 kPa, a pressure-reducing device is required to be installed. Note that water pressure overnight can reach 150% of the daytime measure.**

FAILURE TO INSTALL ACCORDING TO THESE INSTRUCTIONS WILL VOID WARRANTY

### INSTALLATION

Before attempting any work involving mains water supply lines, ensure the water supply is shut off.

Isolating valves (preferably with filters) must be installed at the point of connection. (not supplied with mixer)

#### Assembly

This mixer tap is already pre-assembled and tested. Do not disassemble, as this will void the warranty.

Remove the mixer tap from its packaging. Threaded studs [20] and fixing nuts [19], a horseshoe-shaped fixing plate [18], rubber seal [17] and flexible connectors [22] are supplied.

#### Flexible Connectors (Tails)

Attach the threaded studs [20] and braided flexible connectors [22] to the base prior to mounting. After checking all threads are clean, screw the connectors in by hand.

Attach the hot water connector to the inlet marked "H". Attach the cold water connector to the inlet marked "C". Give each connector a small extra turn (using hand tools) just enough so they will not be undone by hand. Ensure you can identify hot connector from cold.

**AVOID OVER-TIGHTENING.**

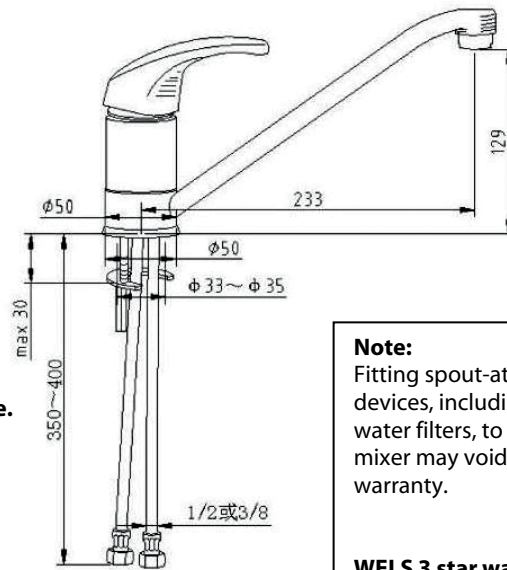

**Note:**  
Fitting spout-attached devices, including water filters, to this mixer may void warranty.

**WELS 3 star water efficiency rating.**  
**9.0 litres per minute.**

#### Mounting

Fit the large "O" ring [16] into the base of the dress ring [15]. Screw the threaded brass fixing studs into the tap base by hand (plain thread end first) if not already done so. Feed the connectors and fixing studs through the mounting hole from above. From below, apply the rubber seal [17], fixing plate [18] (flat side up) and fixing nuts [19]. Align the tap correctly before fully tightening the fixing nuts [19].

#### Water Connection

It is essential to the performance of your mixer tap that all lines are properly flushed to remove any debris (**failure to do so may void warranty**). Once clean, connect to hot and cold stop valves (water supply lines). Once connections are tight, open stop valves and check mixer operation for leaks.

### CARE & MAINTENANCE

Unscrew and clean the spout aerator [14] periodically - especially if you notice a drop in water pressure.

The polished chrome-plated finish on your mixer tap will resist stains and dirt build-up.

Clean with a soft cloth and warm soapy water as necessary – rinse and dry after cleaning. Avoid using abrasive or acid based cleaning products.

### WARRANTY

This mixer tap is warranted to be free from manufacturing defects for a period of 10 Years: 5 years only (parts & labour) plus an additional 5 years on the Cartridge (parts only), when used in a domestic situation.

**This warranty does not cover against normal wear and may be voided if the product is misused or not installed in accordance with these instructions.**

Note: Fitting spout-attached devices, including water filters, to this mixer may void warranty.

In the event this product is rendered obsolete and a replacement product is required, Tasman Sinkware reserves the right to supply a product of equal substitution at their discretion.

### SERVICE

**If the problem represents a danger, or damage to property may occur, immediately shut off the water supply.**

If the mixer tap requires servicing, please contact your plumber (preferably the one who installed it).

Most problems occur due to contaminated supply lines or water pressure exceeding 600kPa.

If the Plumber is satisfied that the problem is not due to poor installation, contact T2 Services Pty Ltd for assistance on:

Ph: (07) 5596 0738

Fax: (07) 5527 3353

Email: oliveri@t2services.com.au

**If a warranty service call finds that the mixer tap is not at fault, T2 Services Pty Ltd reserves the right to pass on any callout fee to the householder.**